

# General Fitting Instruction

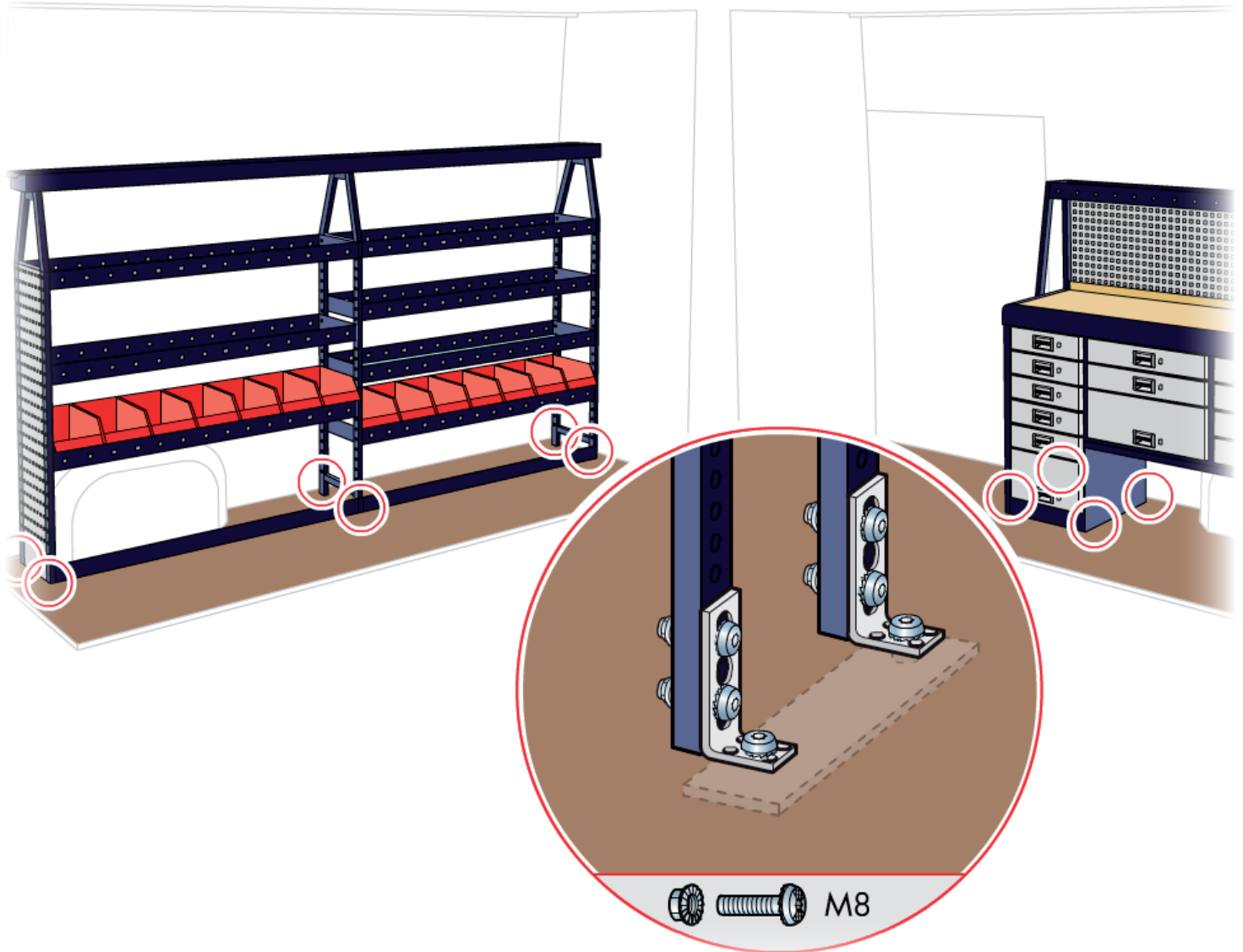

## Introduction

These mounting instructions show how a racking system should be installed in the vehicle. The modular racking system can be configured in a great variety of ways, but these instructions show a common configuration. These mounting instructions must be adhered to regardless of the type of racking system, but positioning of angle brackets must be adapted to the racking system and the vehicle.

## Preparation

Unpack, check number and type of products.

## Preliminary assembly

Read the accompanying mounting instructions for the product in question. Assemble as much as possible outside the car – it is important that this take place on a flat surface.

## Vehicle lining

If protective lining is to be fitted in the cargo space, this should be done before the racking system is lifted into the vehicle. But mark where the vehicle's structural members are so that you can position the angle brackets there when installing the racking system.

## Installing in the vehicle

Lift the racking system into the vehicle and adjust into position. The racking system should then be mounted to the walls using the fastening components indicated. Bolts must be used for attachment where possible, otherwise rivets. Holes drilled into the vehicle's bodywork need rust protection, and metal swarf must be cleaned up to reduce the risk of corrosion to the vehicle's bodywork.

Mount the fixing plate for the racking, before you place the floor after drilling etc into the vehicle

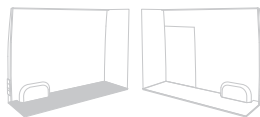
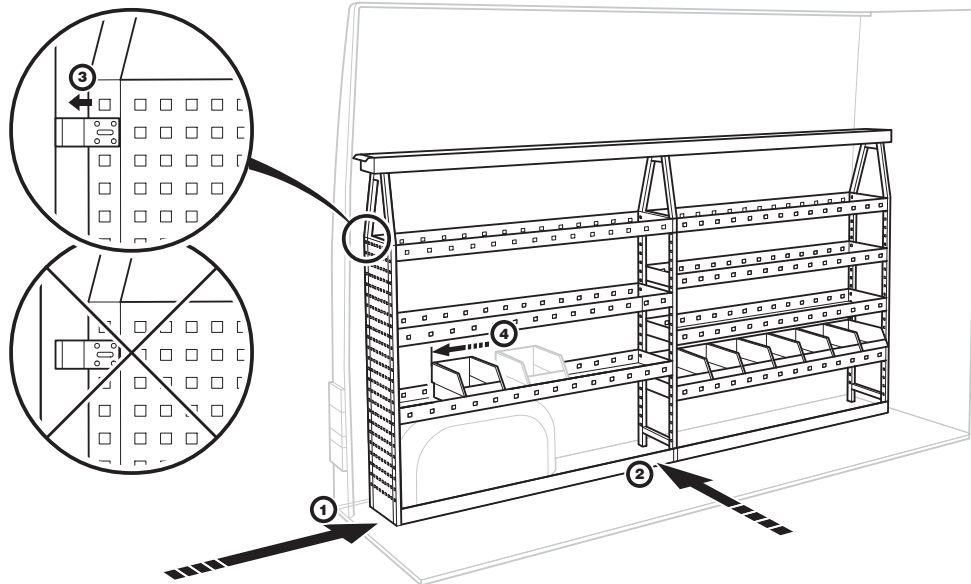
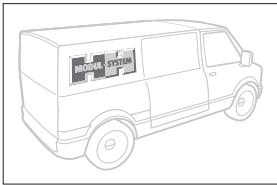
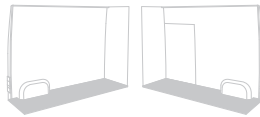
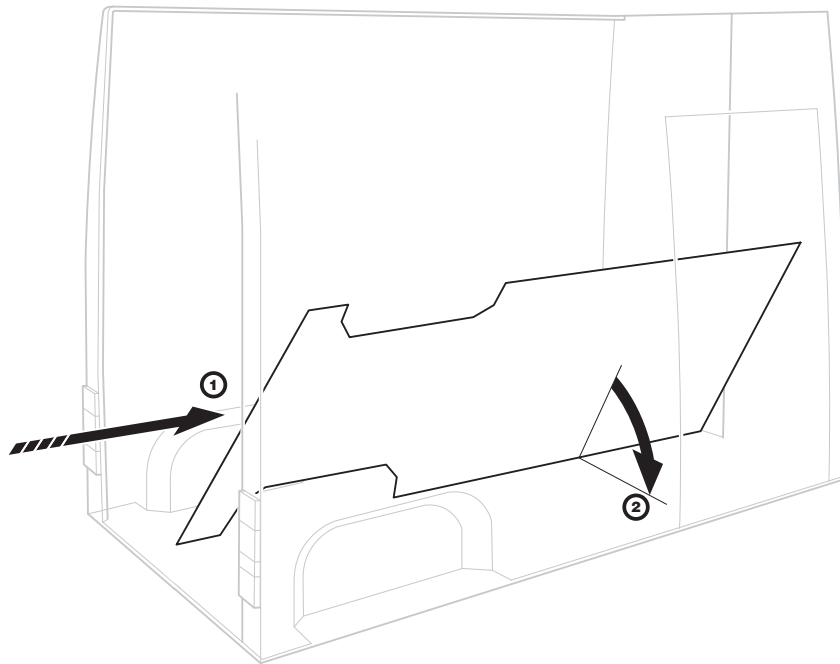
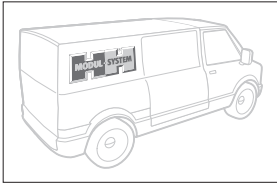

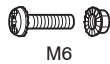
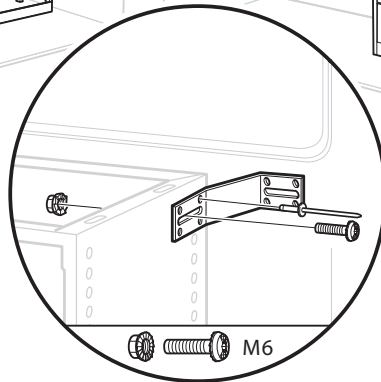
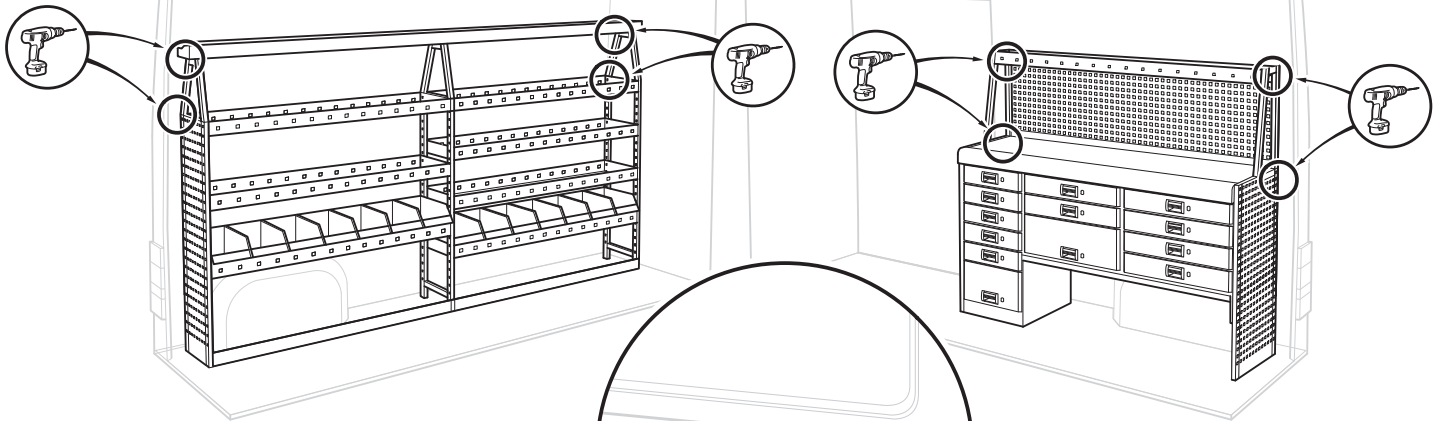
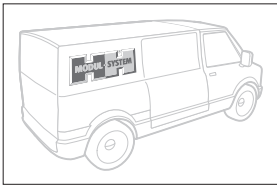

M6

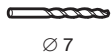

Ø 7



(13-29)

Ø 5

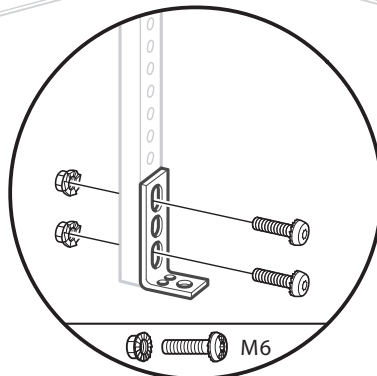
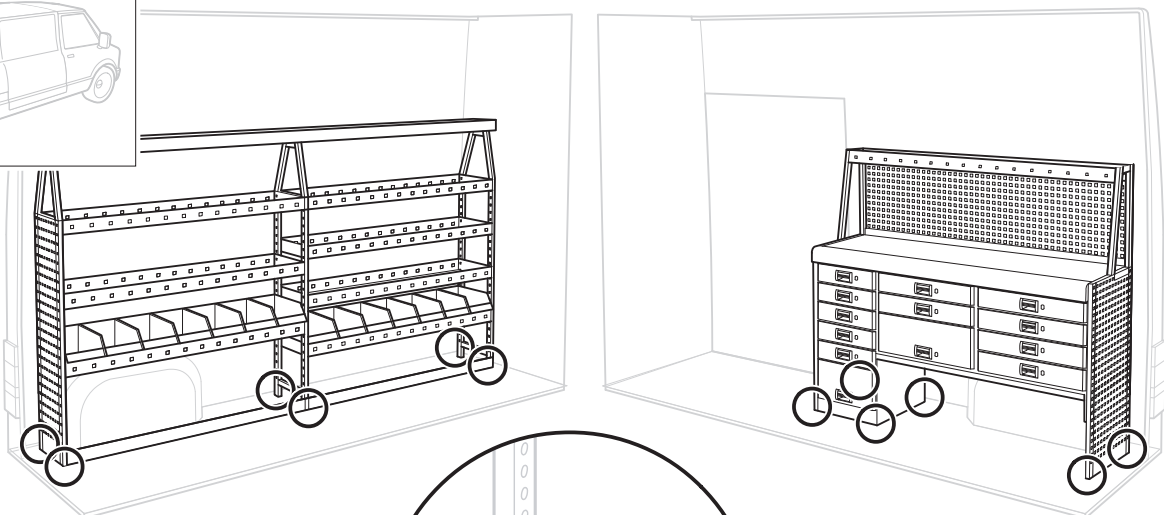
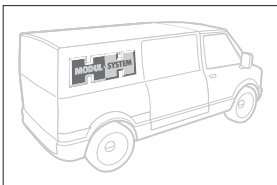

M6



M6

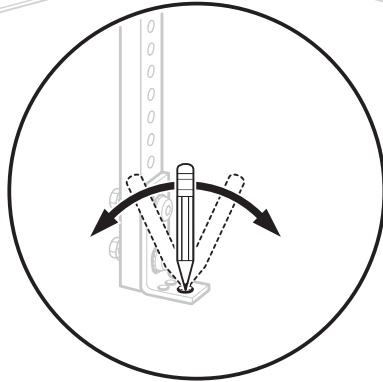
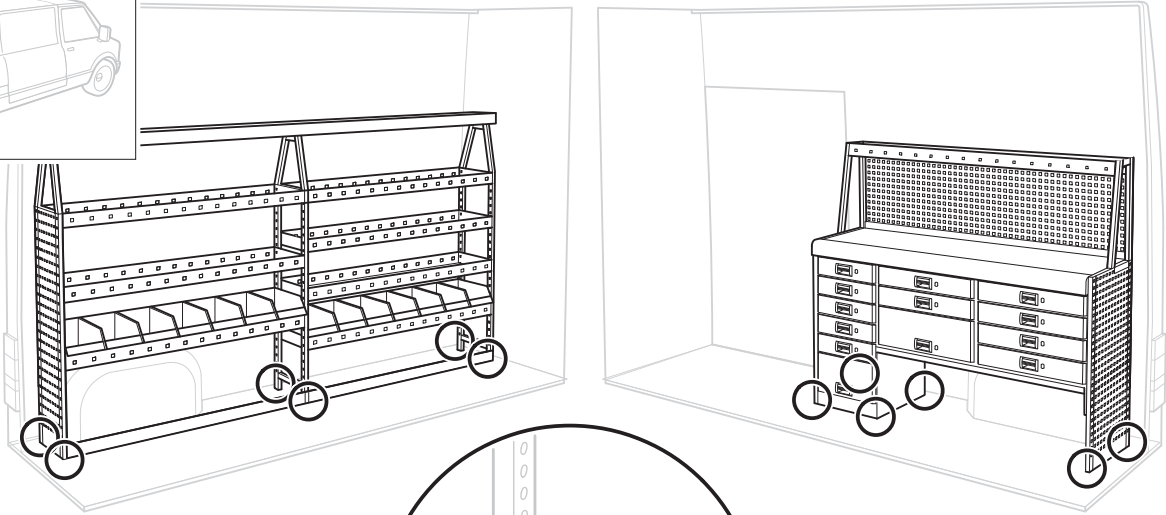
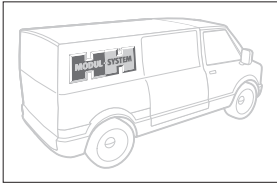

M6



Ø 7



(13-29)

Ø 5

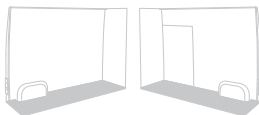
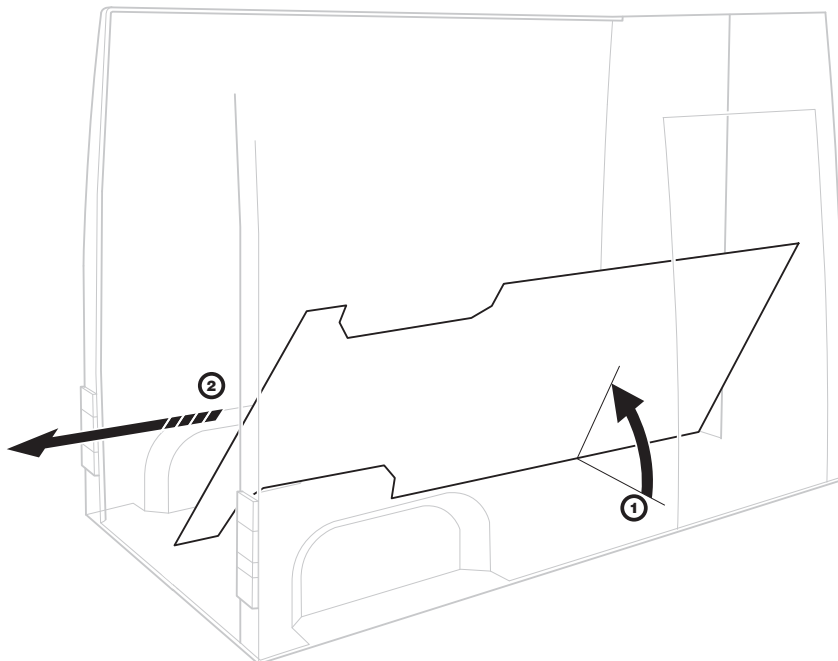
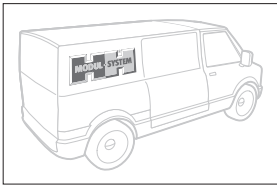

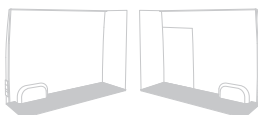
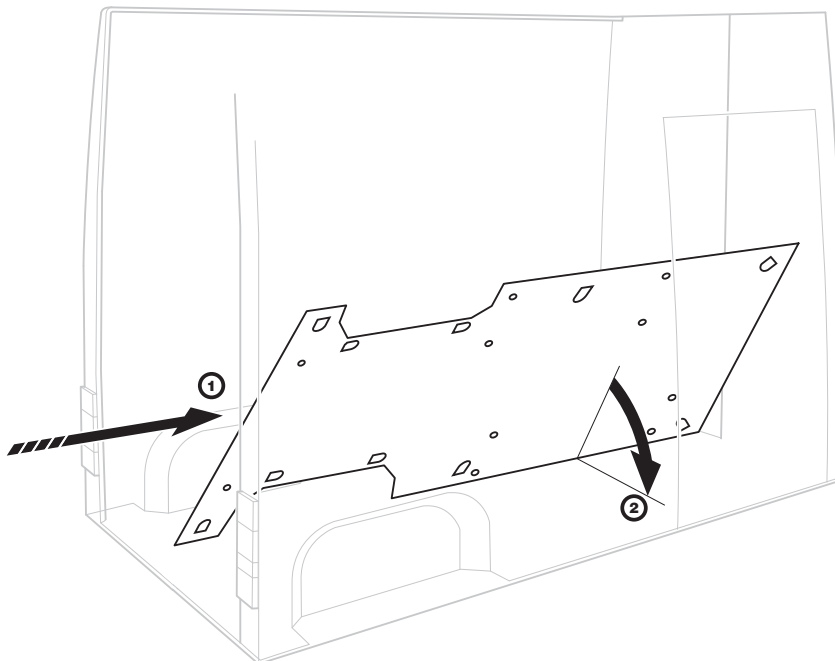
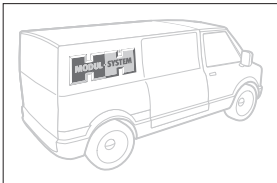
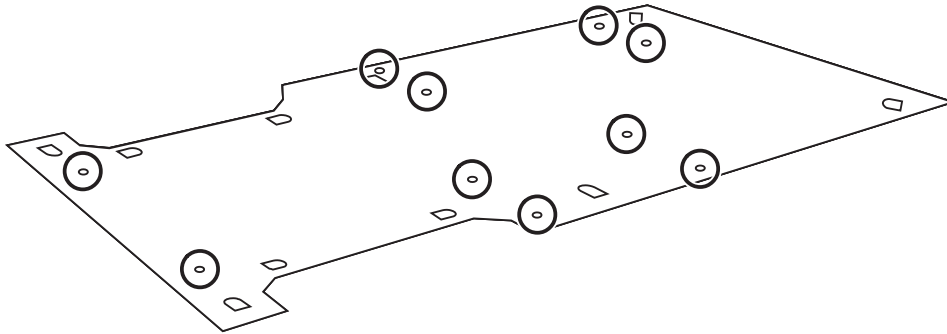
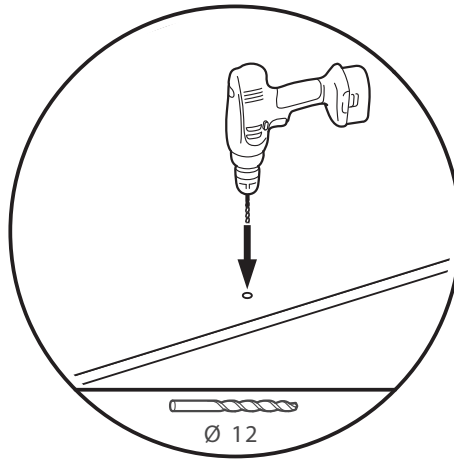
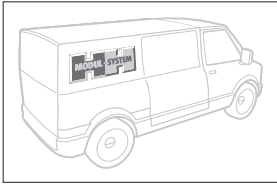

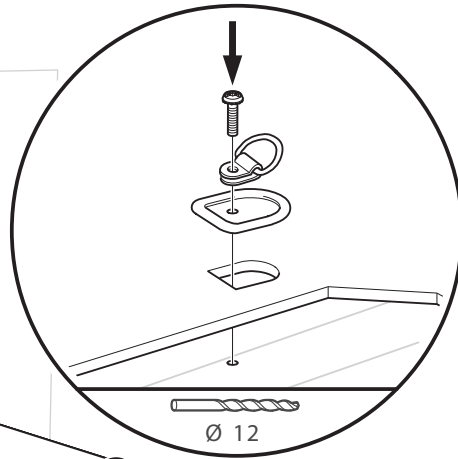
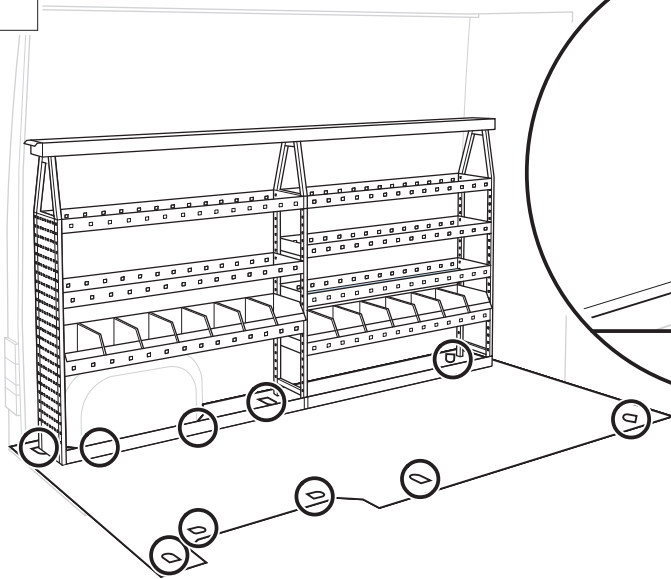
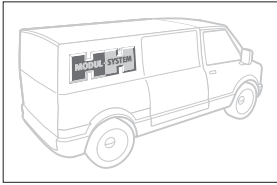

M6



Ø 7

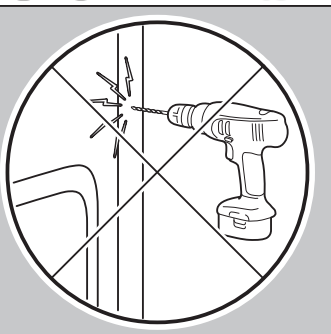
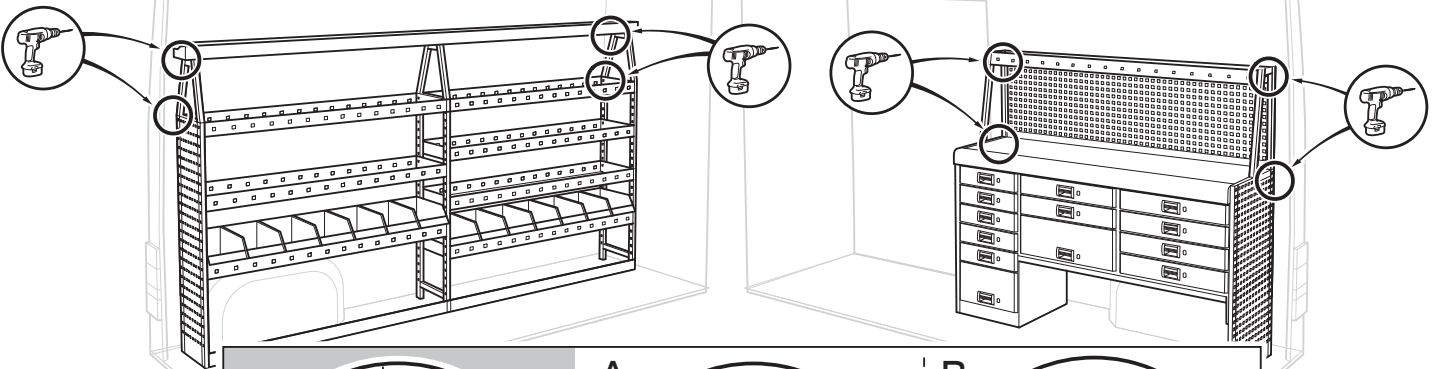
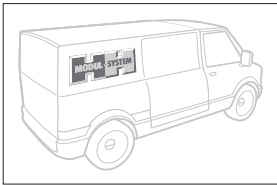

A

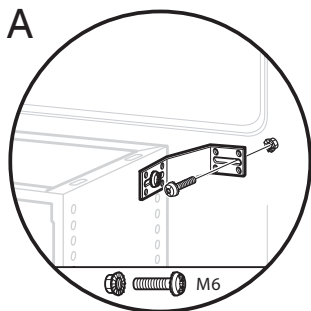

M6

B

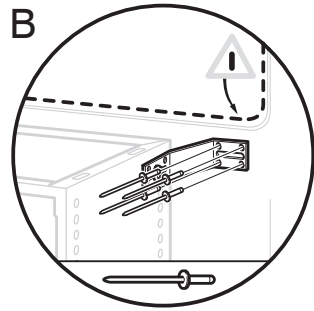

M6



Ø 7



(13-29)



Ø 5

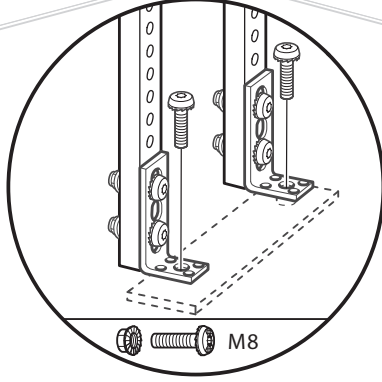
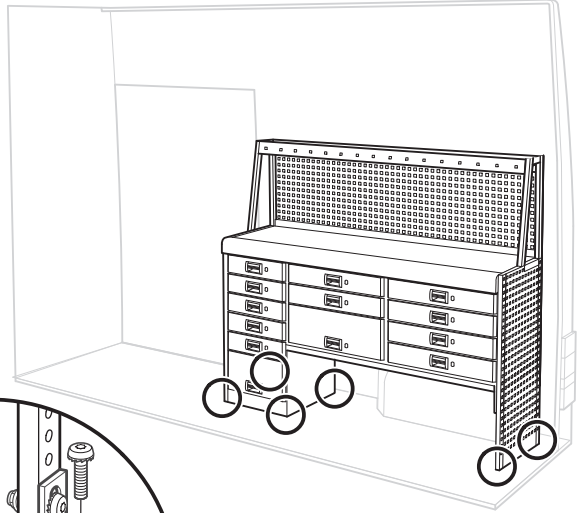
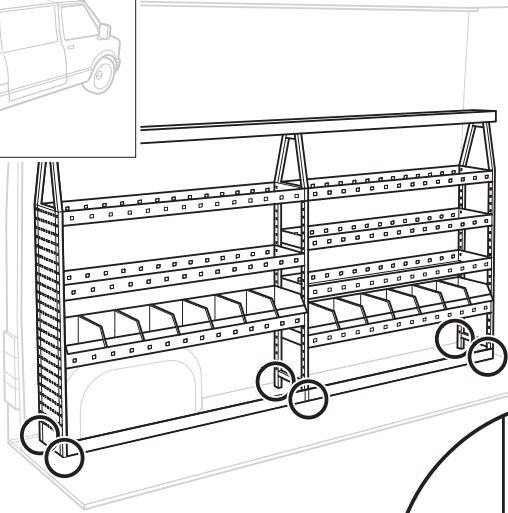
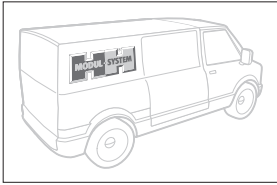

M8



M6

Ø 7

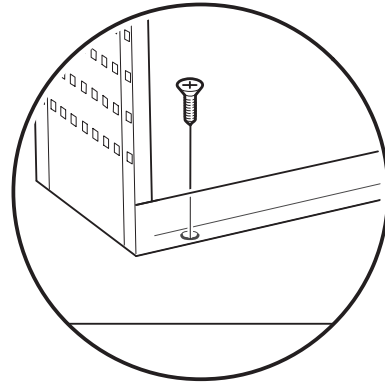
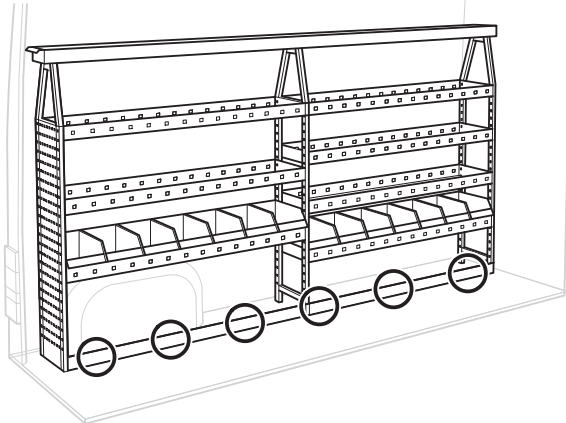
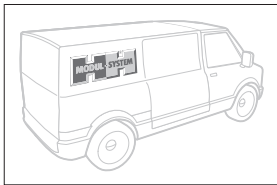



Modul-System HH AB

Box 148, SE-431 22 Mölndal, Sweden, +46 31 746 87 00,  
[www.modul-system.com](http://www.modul-system.com)